

**QUASISTATIC PERIODIC CONTACT PROBLEM  
FOR A VISCOELASTIC LAYER, A CYLINDER,  
AND A SPACE WITH A CYLINDRICAL CAVITY**

V. M. Aleksandrov and A. V. Mark

UDC 539.3

*This paper considers the contact problem of interaction of a rigid die, a rigid band, and a rigid insert with a viscoelastic layer, a viscoelastic cylinder, and viscoelastic space with a cylindrical cavity, respectively. It is assumed that the die, band, and insert move at a constant velocity along the boundaries of the viscoelastic bodies. In the first stage, the displacement of the boundaries of the above-mentioned bodies is determined as a function of the applied normal loads ignoring friction in the contact area. In the second stage, integral equations are derived to determine contact pressure in the contact problems. In the third stage, approximate solutions of the integral equations are constructed using a modified Multhopp–Kalandia method.*

**Key words:** viscoelastic layer, cylinder, displacement die, contact pressure.

**1. Solution of the Auxiliary Problem.** Let a die, a band, and an insert move at constant velocity  $V$  along the boundaries of a viscoelastic layer, a viscoelastic cylinder, and viscoelastic space with a cylindrical cavity, respectively (Fig. 1). We assume that the viscoelastic bodies are described by the Kelvin model [1]. The motion of the die will be considered in Cartesian coordinates  $x$ ,  $y$ , and  $z$ , and the motion of the band and the insert in cylindrical coordinates  $r$ ,  $\varphi$ , and  $z$ .

We first derive relations between displacements of the boundaries of the layer, cylinder, and space with a cylindrical cavity and the normal loads applied to them  $q(\eta, z)$  using an elastic formulation of the problem (the loads are motionless), and then, according to [1], we obtain relations between displacements of the boundaries of the viscoelastic bodies and the loads moving on them at a constant velocity.

We write the equations of elastic equilibrium

$$2(1 - \nu) \operatorname{grad} \operatorname{div} \mathbf{u} - (1 - 2\nu) \operatorname{rot} \operatorname{rot} \mathbf{u} = 0 \quad (1.1)$$

and the boundary conditions

$$\begin{aligned} \sigma_{\xi\xi}(l, \eta, z) = -q(\eta, z) \quad (|z| \leq a), \quad \sigma_{\xi\xi}(l, \eta, z) = 0 \quad (|z| > a), \\ \sigma_{\xi\eta}(l, \xi, z) = \sigma_{\xi z}(l, \eta, z) = 0, \end{aligned} \quad (1.2)$$

$$u_{\xi}(0, \eta, z) = u_{\eta}(0, \eta, z) = u_z(0, \eta, z) = 0$$

(the last condition is satisfied only for the layer). In (1.1) and (1.2),  $u_{\xi}$ ,  $u_{\eta}$ , and  $u_z$  are the components of the displacement vector  $\mathbf{u}$  in the directions  $\xi$ ,  $\eta$ , and  $z$ , respectively,  $\sigma_{\xi\xi}$  is the normal stress,  $\sigma_{\xi\eta}$  and  $\sigma_{\xi z}$  are the tangential stresses,  $\nu$  is Poisson ratio, and  $l$  is the thickness of the layer or the radius of the cylinder or cylindrical cavity; by  $\xi$  is meant the coordinate  $x$  (or  $r$ ), and by  $\eta$  the coordinate  $y$  (or  $\varphi$ ).

---

Ishlinskii Institute of Problems of Mechanics, Russian Academy of Sciences, Moscow 119526; alexand@ipmnet.ru. Translated from *Prikladnaya Mekhanika i Tekhnicheskaya Fizika*, Vol. 50, No. 5, pp. 162–168, September–October, 2009. Original article submitted January 29, 2008; revision submitted September 19, 2008.

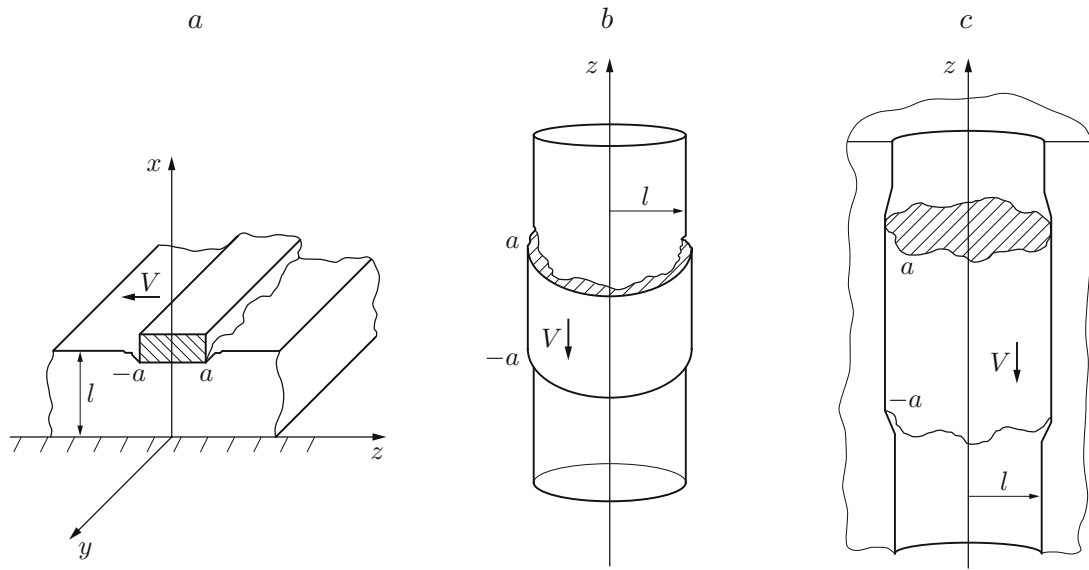

Fig. 1. Diagrams of contact problems: (a) die; (b) band; (c) insert.

Equations (1.1) are solved using a Fourier transform in the coordinate  $z$  and (due to the periodicity of the problems) a series expansion in the coordinate  $\eta$ :

$$\mathbf{u} = e^{-i\beta\eta} \mathbf{u}_\beta, \quad \mathbf{u}_\beta = \frac{1}{2\pi} \int_{-\infty}^{\infty} \mathbf{U}_\beta(\alpha, \xi) e^{-i\alpha z} d\alpha. \quad (1.3)$$

In this case,

$$q(\eta, z) = e^{-i\beta\eta} q_\beta(z), \quad q_\beta(z) = \frac{1}{2\pi} \int_{-\infty}^{\infty} Q_\beta(\alpha) e^{-i\alpha z} d\alpha. \quad (1.4)$$

Here  $\mathbf{u}_\beta$  is the displacement amplitude vector with the components  $u_{\beta\xi}$ ,  $u_{\beta\eta}$ , and  $u_{\beta z}$ ,  $\mathbf{U}_\beta$  and  $Q_\beta(\alpha)$  are Fourier transforms of the functions  $\mathbf{u}_\beta$  and  $q_\beta(z)$ , and  $\beta$  is the wave frequency on the surface of the die, band, or insert.

Problem (1.1) with boundary conditions (1.2) subject to (1.3), (1.4) is solved under the following additional assumptions: for  $z \rightarrow \infty$ , stress is absent; in the case of the cylinder for  $\xi = 0$ , the stress is limited; in the case of the space with a cylindrical cavity for  $\xi \rightarrow \infty$ , stress is absent. As a result, the normal displacements  $u_\xi$  of the boundaries of the indicated bodies are expressed as

$$u_\xi(l, \eta, z) = \mp \frac{1}{\pi\Theta} e^{-i\beta\eta} \int_{-a}^a q_\beta(\zeta) \int_0^\infty \frac{L_i(u)}{u} \cos \frac{u}{l} (\zeta - z) du d\zeta, \quad \Theta = \frac{G}{1-\nu}, \quad (1.5)$$

where for the layer,

$$L_1(u) = \frac{(2\alpha \sinh(2s) - 4s)u}{s(2\alpha \cosh(2s) + \alpha^2 + 1 + 4s^2)}, \quad s = \sqrt{u^2 + l^2\beta^2}, \quad \alpha = 3 - 4\nu, \quad (1.6)$$

for the cylinder,

$$L_2(u) = k_\beta(u)/l_\beta(u), \quad (1.7)$$

and for the space with a cylindrical cavity,

$$L_3(u) = m_\beta(u)/n_\beta(u) \quad (1.8)$$

( $a$  is the half-length of the contact area and  $G$  is the shear modulus). In Eq. (1.5) and below, the upper sign (plus or minus) corresponds to the problem for a layer or cylinder, and the lower sign (plus or minus) corresponds to the

problem for space with a cylindrical cavity. In the problem for a cylinder or space with a cylindrical cavity,  $\beta$  is an integer. The functions  $k_\beta(u)$ ,  $l_\beta(u)$ ,  $m_\beta(u)$ , and  $n_\beta(u)$  have the form [2]

$$\begin{aligned} \left\{ \begin{array}{l} k_\beta(u) \\ m_\beta(u) \end{array} \right\} &= -\frac{\beta^2}{2\alpha u^2} \left\{ \begin{array}{l} \omega_\beta(u) \\ \Omega_\beta(u) \end{array} \right\}^3 \left(1 + \frac{\beta^2}{u^2}\right) - \frac{\beta^2}{u^3} \left\{ \begin{array}{l} \omega_\beta(u) \\ \Omega_\beta(u) \end{array} \right\}^2 - \frac{1}{2} \left\{ \begin{array}{l} \omega_\beta(u) \\ \Omega_\beta(u) \end{array} \right\} \left(1 - \frac{\beta^2}{\alpha u^2}\right) + \frac{1}{u}, \\ \left\{ \begin{array}{l} l_\beta(u) \\ n_\beta(u) \end{array} \right\} &= \pm \frac{1}{2} u \left\{ \begin{array}{l} \omega_\beta(u) \\ \Omega_\beta(u) \end{array} \right\}^3 \left[ \frac{\alpha\beta^2}{u^4} - \left(1 + \frac{\beta^2}{u^2}\right)^3 + \frac{\beta^2}{u^4} \left(1 + \frac{\beta^2}{u^2}\right) \right] \\ &\pm \left\{ \begin{array}{l} \omega_\beta(u) \\ \Omega_\beta(u) \end{array} \right\}^2 \left[ \left(1 + \frac{\beta^2}{u^2}\right) \left(1 - \frac{\alpha\beta^2}{u^2}\right) + \frac{\alpha\beta^2}{u^4} \right] \pm \frac{1}{2} u \left\{ \begin{array}{l} \omega_\beta(u) \\ \Omega_\beta(u) \end{array} \right\} \left[ \frac{\alpha}{u^2} + \left(1 + \frac{\beta^2}{u^2}\right)^2 - \frac{\beta^2}{u^4} \right] \pm \frac{\alpha(\beta^2 - 1)}{u^2} \mp 1, \end{aligned} \tag{1.9}$$

where  $\omega_\beta(u) = I_\beta(u)/[I'_\beta(u)]$ ,  $\Omega_\beta(u) = K_\beta(u)/[K'_\beta(u)]$ ,  $\alpha = 2(1 - \nu)$ , and  $I_\beta(u)$  and  $K_\beta(u)$  are modified Bessel functions of the first and second kind of order  $\beta$ , respectively.

Let us consider the viscoelastic problem. The motion of the load will be considered in a coordinate system which moves at constant velocity  $V$  in the negative  $z$  direction together with the load. The motion is considered steady-state. In these coordinates, the displacement and load  $q(\eta, z)$  do not depend on time.

Thus, in the elastic formulation of the problem, the amplitudes of the normal displacements are given by relation (1.5), and in the case of the viscoelastic layer, cylinder, and space with a cylindrical cavity, expression (1.5), according to the Volterra principle, takes the following form (by analogy with formula (49.2) in [1]:

$$u_{\beta\xi}(z, l) = \mp \frac{1}{\pi\Theta_f} \int_{-a}^a q_\beta(\zeta) \left[ K\left(\frac{\zeta - z}{l}\right) + \int_{-\infty}^0 p(-\tau) K\left(\frac{\zeta - z - V\tau}{l}\right) d\tau \right] d\zeta. \tag{1.10}$$

Here

$$K(t) = \int_0^\infty \frac{L_i(u)}{u} \cos(ut) du, \quad p(t) = k \exp\left(-\frac{t}{\lambda}\right), \quad k = \frac{1}{\gamma} \left(1 - \frac{\gamma}{\lambda}\right), \quad \Theta_f = \frac{G_f}{1 - \nu},$$

$\lambda$  and  $\gamma$  are viscous constants, and  $G_f$  is the instantaneous shear modulus.

**2. Derivation of the Integral Equation.** We study the contact problem in which the quantity  $u_\xi(\eta, z, l)$  is known and equal to  $\mp\delta(\eta, z)$  and the contact pressure  $q(\eta, z)$  is not known. If the problem for a layer is considered, the quantity  $\delta(\eta, z)$  is understood as the penetration of the die into the layer, and if the problem for a cylinder or space with a cylindrical cavity is considered, the function  $\delta(\eta, z)$  is given by

$$\delta(\eta, z) = \mp(\rho(\eta, z) - l).$$

Here  $\rho = \rho(\eta, z)$  is the equation of the surface of the band or insert.

We assume that the function  $\delta(\eta, z)$  can be written as

$$\delta(\eta, z) = \delta_\beta(z) e^{-i\beta\eta}.$$

It should be noted that the problems in question are superpositions of two problems: the problem for  $\beta = 0$  (flat die, band, and insert) and the problem for  $\beta \neq 0$  (curved die, band, and insert).

In the vicinity of the value  $u = 0$ , all functions  $L_i(u)$  ( $i = 1, 2, 3$ ) in (1.6)–(1.8) have the form  $L(u) = Cu + O(u^3)$ , except for the function  $L_2(u)$  for  $\beta = 1$ . In the latter case for  $\beta = 1$  in (1.6), the following expansions hold in the vicinity of zero:

$$k_1(u) = -\frac{1}{4} \alpha^{-1} u - \frac{1}{24} \frac{2\alpha - 5}{\alpha} u^3 + O(u^5), \quad l_1(u) = \left(-\frac{1}{8} + \frac{1}{32} \alpha\right) u^4 + O(u^6),$$

i.e., at  $\beta = 1$  the integral (1.5) containing  $L_2(u)$  diverges. In the present paper, this case is not considered.

We introduce the following dimensionless quantities and notation:

$$\varphi(z') = \frac{q(z)}{\Theta_f}, \quad \varepsilon = \frac{l}{a}, \quad \mu = \frac{\lambda V}{a}, \quad g(z') = \frac{\delta_\beta(z)}{a}, \quad z' = \frac{z}{a}, \quad \zeta' = \frac{\zeta}{a}, \quad \tau' = \frac{\tau}{\lambda}, \quad w' = \zeta' - z'. \tag{2.1}$$

In the problem for a layer, it is necessary to introduce the quantity  $\beta' = \beta a$ . Taking into account (2.1), we write Eq. (1.10) in the form

$$\int_{-1}^1 \varphi(\zeta) \left[ K_1\left(\frac{w}{\varepsilon}\right) + k\lambda K_2\left(\frac{w}{\varepsilon}\right) \right] d\zeta = \pi g(z); \quad (2.2)$$

$$K_1\left(\frac{w}{\varepsilon}\right) = \int_0^\infty \frac{L_i(u)}{u} \cos\left(\frac{uw}{\varepsilon}\right) du; \quad (2.3)$$

$$K_2\left(\frac{w}{\varepsilon}\right) = \int_{-\infty}^0 e^\tau \int_0^\infty \frac{L_i(u)}{u} \cos\left(u \frac{w - \mu\tau}{\varepsilon}\right) du d\tau. \quad (2.4)$$

Here and below, primes are omitted. Using the representation

$$\ln |t| = \int_0^\infty \frac{e^{-u} - \cos(ut)}{u} du,$$

we separate the logarithmic part in Eq. (2.3). As a result, we obtain

$$K_1\left(\frac{w}{\varepsilon}\right) = -\ln \left| \frac{w}{\varepsilon} \right| + F_1\left(\frac{w}{\varepsilon}\right), \quad F_1\left(\frac{w}{\varepsilon}\right) = -\int_0^\infty \frac{[1 - L_i(u)] \cos(uw/\varepsilon) - e^{-u}}{u} du.$$

Equation (2.4) can be transformed as

$$\begin{aligned} K_2\left(\frac{w}{\varepsilon}\right) &= \int_0^\infty \frac{L_i(u)}{u} \int_{-\infty}^0 e^\tau \cos\left(u \frac{w - \mu\tau}{\varepsilon}\right) d\tau du \\ &= \int_0^\infty \frac{L_i(u)}{u} \frac{\varepsilon^2 \cos(uw/\varepsilon) - \varepsilon\mu u \sin(uw/\varepsilon)}{\varepsilon^2 + \mu^2 u^2} du = J_1\left(\frac{w}{\varepsilon}\right) + J_2\left(\frac{w}{\varepsilon}\right). \end{aligned}$$

Here

$$J_1\left(\frac{w}{\varepsilon}\right) = \varepsilon^2 \int_0^\infty \frac{L_i(u)}{u} \frac{\cos(uw/\varepsilon)}{\varepsilon^2 + \mu^2 u^2} du, \quad J_2\left(\frac{w}{\varepsilon}\right) = -\varepsilon\mu \int_0^\infty \frac{L_i(u)}{\varepsilon^2 + \mu^2 u^2} \sin(uw/\varepsilon) du. \quad (2.5)$$

Performing transformations to improve the convergence of the integrals in (2.5), we write the kernel of the integral equation (2.2) in the form

$$M(w) = -\ln \left| \frac{w}{\varepsilon} \right| + F(w), \quad (2.6)$$

where

$$F(w) = F_1\left(\frac{w}{\varepsilon}\right) + k\lambda \left[ \sum_{i=1}^3 F_i\left(\frac{w}{\varepsilon}\right) + E_1(w) \right] \quad (2.7)$$

for the problem for a layer and

$$F(w) = F_1\left(\frac{w}{\varepsilon}\right) + k\lambda \left[ J_1\left(\frac{w}{\varepsilon}\right) + F_3\left(\frac{w}{\varepsilon}\right) + E_2(w) \right] \quad (2.8)$$

for the problem for a cylinder and space with a cylindrical cavity. In (2.7) and (2.8), we have

$$F_2\left(\frac{w}{\varepsilon}\right) = \mu^2 \int_0^\infty \frac{[1 - L(u)]u}{\varepsilon^2 + \mu^2 u^2} \cos\left(\frac{uw}{\varepsilon}\right) du, \quad F_3\left(\frac{w}{\varepsilon}\right) = \varepsilon\mu \int_0^\infty \frac{1 - L(u)}{\varepsilon^2 + \mu^2 u^2} \sin\left(\frac{uw}{\varepsilon}\right) du,$$

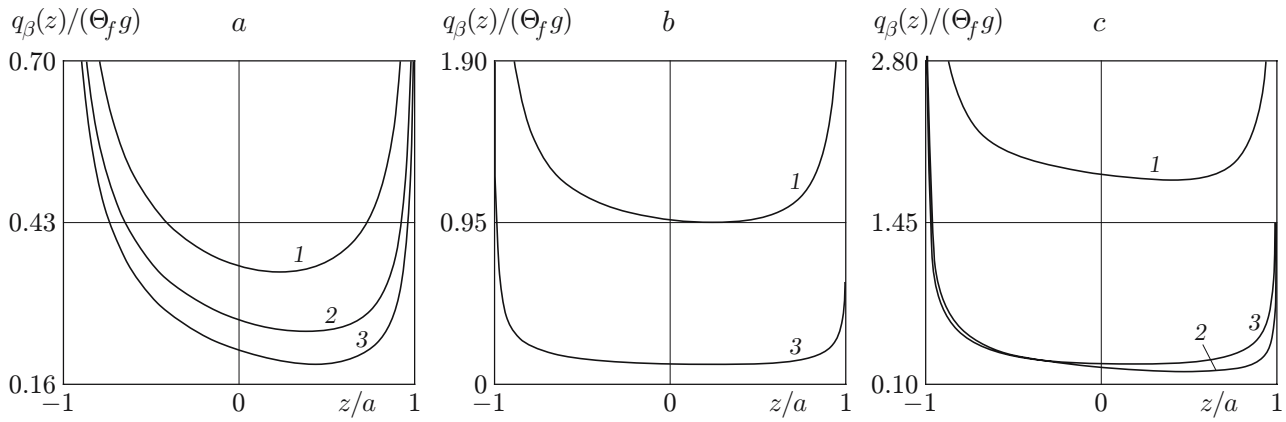

Fig. 2. Contact pressure distribution along in the  $z$  direction for  $\beta = 0$  (a), 1 (b), and 2 (c); curves 1–3 refer to the contact pressures under the die (1), under the band (2), and under the insert (3).

$$E_1(w) = \exp\left(\frac{w}{\mu}\right) \text{Ei}\left(-\frac{w}{\mu}\right) - \ln\left|\frac{w}{\varepsilon}\right|, \quad E_2(w) = -\frac{1}{2} \left[ \exp\left(-\frac{w}{\mu}\right) \text{Ei}\left(\frac{w}{\mu}\right) - \exp\left(\frac{w}{\mu}\right) \text{Ei}\left(-\frac{w}{\mu}\right) \right],$$

where  $\text{Ei}(x)$  is an integral exponential function [3]. The function  $F(w)$  is continuous.

Expressions (2.7) and (2.8), in fact, define the same function, but, because the behavior of the functions  $L_i(u)$  at infinity is different, for the best convergence of the integrals, it is reasonable to use these expressions in the corresponding problems.

Thus, we have the equation

$$\int_{-1}^1 \varphi(\zeta) M(w) d\zeta = \pi g(z) \quad (2.9)$$

with kernel (2.6).

**3. Solution of the Contact Problem for Sharp-Edged Die, Band, and Insert.** In the case of sharp-edged die, band, and insert, the solution of the integral equation (2.9) with kernel (2.6) can be written as

$$\varphi(z) = \Phi(z)(1 - z^2)^{-1/2},$$

where  $\Phi(z) \in C_n(-1, 1)$  (see [4, Theorem 2.1]).

For this problem, we set  $g(z) \equiv g$ . Equation (2.8) with the kernel (2.6) is solved using a modified Multhopp–Kalandia method [2]. For the function  $\Phi(z)$ , we construct a Lagrangian interpolation polynomial by nodes

$$z_n = \cos \theta_n, \quad \theta_n = \pi(2n - 1)/(2N) \quad (n = 1, 2, \dots, N),$$

which are zeroes of the Chebyshev polynomial  $T_N(z)$ . This polynomial has the form

$$\Phi(\cos \vartheta) = \frac{1}{N} \sum_{n=1}^N \Phi_n \left( 1 + 2 \sum_{m=1}^{N-1} \cos m\theta_n \cos m\vartheta \right). \quad (3.1)$$

Transforming to the new variables  $z = \cos \vartheta$  and  $\zeta = \cos \psi$ , we write Eq. (2.9) in the form

$$\int_0^\pi \Phi(\cos \psi) \ln \left| \frac{\cos \psi - \cos \vartheta}{\varepsilon} \right| d\psi = \pi g - \int_0^\pi \Phi(\cos \psi) F(\cos \psi - \cos \vartheta) d\psi, \quad (3.2)$$

$$\vartheta \in [0, \pi].$$

Substituting (3.1) into Eq. (3.2) and using the relation

$$-\int_0^\pi \cos s\psi \ln \left| \frac{\cos \psi - \cos \vartheta}{\varepsilon} \right| d\psi = \begin{cases} \pi \ln(2\varepsilon), & s = 0, \\ \pi s^{-1} \cos s\vartheta, & s \neq 0 \end{cases}$$

and the Gauss quadrature formula

$$\int_0^{\pi} \chi(\psi) d\psi = \frac{\pi}{N} \sum_{n=1}^N \chi(\theta_n),$$

we obtain

$$\sum_{n=1}^N \Phi_n \left( \ln(2\varepsilon) + 2 \sum_{m=1}^{N-1} \frac{\cos m\theta_n \cos m\vartheta}{m} \right) = Ng - \sum_{n=1}^N \Phi_n F(\cos \theta_n - \cos \vartheta).$$

Using the collocation method, i.e., setting  $\vartheta = \theta_k$ , we obtain the following system of linear algebraic equations for determining  $\Phi_n$ :

$$\sum_{n=1}^N \Phi_n \left( \ln(2\varepsilon) + 2 \sum_{m=1}^{N-1} \frac{\cos m\theta_n \cos m\theta_k}{m} + F(\cos \theta_n - \cos \theta_k) \right) = Ng,$$

$$k = 1, 2, \dots, N.$$

**4. Examples of Numerical Calculations.** As a viscoelastic medium we consider rubber for which  $\nu = 0.3$  and  $\lambda/\gamma = 1001$ .

Figure 2 shows the contact pressure distributions along the  $z$  coordinate for the bodies considered at  $\beta = 0, 1$ , and  $2$ . Curves 1, 2, and 3 correspond to the contact pressure distributions under the die, band, inset, respectively. The calculations were performed for  $\mu = 10^4$  and  $\varepsilon = 8$ . Curve 2 in Fig. 2b is absent since it corresponds to the case  $\beta = 1$  for the cylinder, which is not considered.

This work was supported by the Russian Foundation for Basic Research (Grant Nos. 08-01-00003, 06-01-00022, 06-08-01595, and 07-08-00730).

## REFERENCES

1. Yu. N. Rabotnov, *Elements of Hereditary Solid-State Mechanics* [in Russian], Nauka, Moscow (1977).
2. V. M. Aleksandrov and B. L. Romalis, *Contact Problems in Machine Engineering* [in Russian], Mashinostroenie, Moscow (1986).
3. I. I. Gradshteyn and I. M. Ryzhik, *Table of Integrals, Series, and Products*, Academic Press, New York (1980).
4. V. M. Aleksandrov and E. V. Kovalenko, *Problems of Mechanics of Continuous Media with Mixed Boundary Conditions* [in Russian], Nauka, Moscow (1986).